

DETALLE DE ESQUINERO

DETALLE TERMINAL

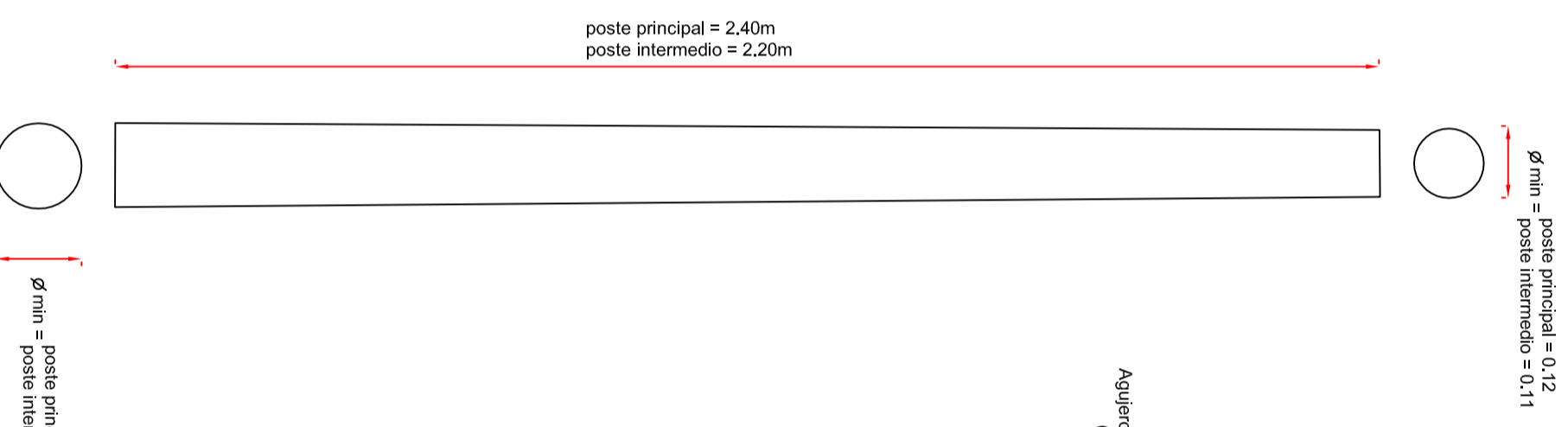

TIPO DE POSTE

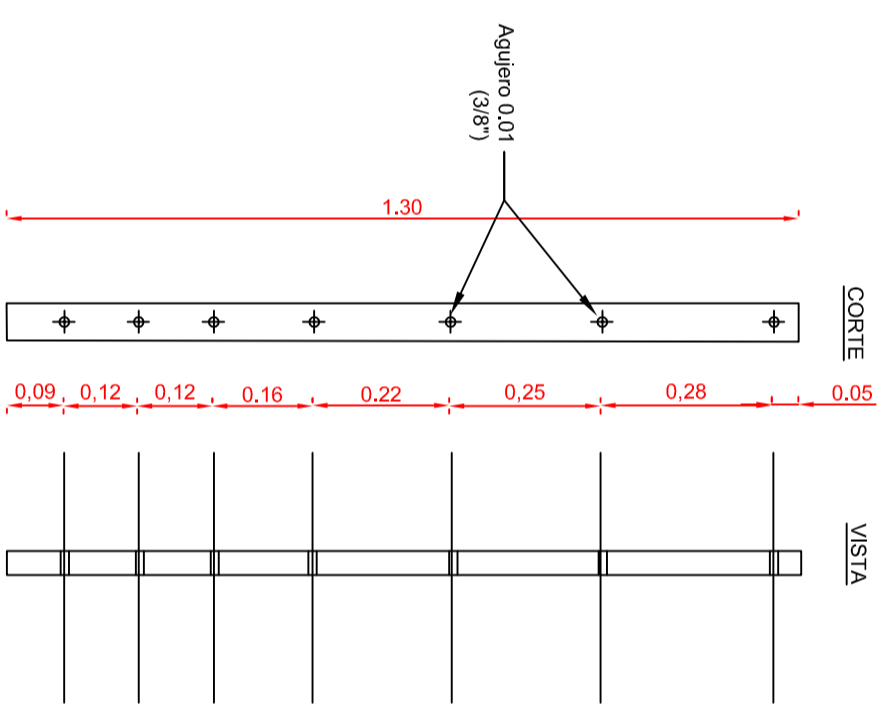

TIPO DE VARILLAS



TORNIQUETE AL AIRE CON RUEDA A CRIQUE Nº 8

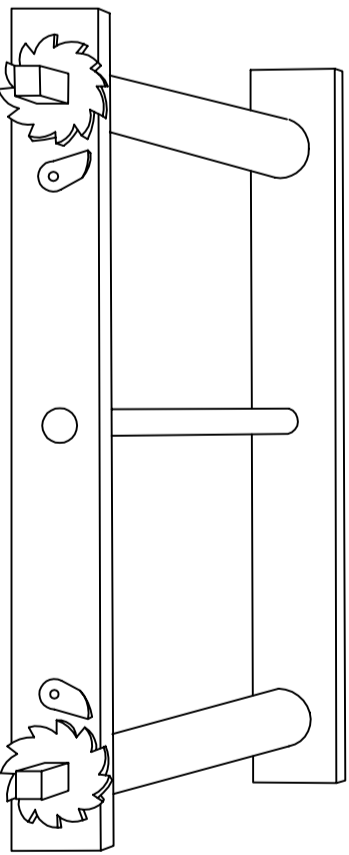

TORNIQUETE DOBLE A CAJON CON RUEDA A CRIQUE Nº 3

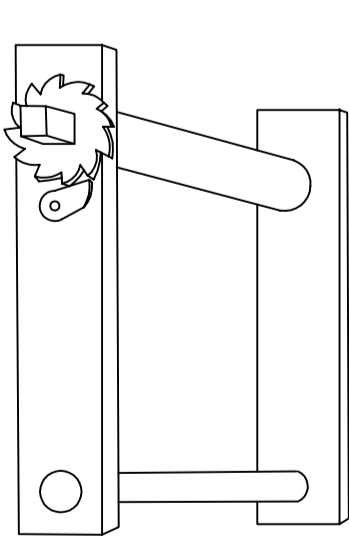

TORNIQUETE MEDIO DOBLE A CAJON CON RUEDA A CRIQUE Nº 3

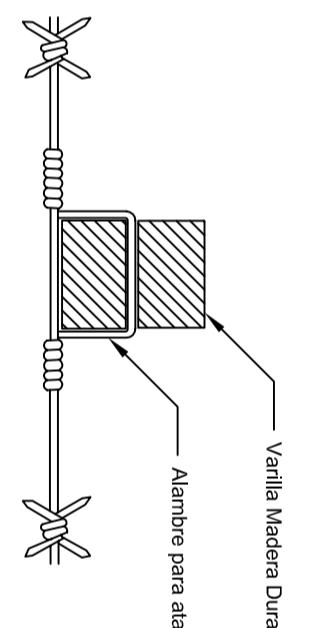

DETALLE DE ATADURAS A LAS VARILLAS

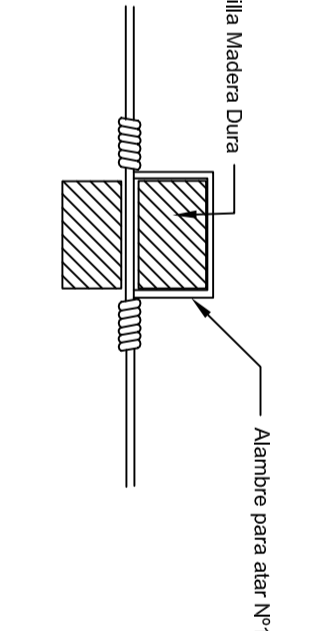

DETALLE DE ATADURAS A LOS POSTES

Utopia Real del edificio principal		Almbrado de 7 hilos	
GERENCIA DE DESARROLLO DE LA INFRAESTRUCTURA		DIMENSIONES EN MIL	
INGENIERIA FERROVIARIA	AREA	PLANO Nº	2   10   3
ROMAL	DEBIDO	INGENIERIA	
FECHA	REVISO	NO. P. DE CADA	
31/07/13			